

# THE ENGINE THAT RUNS ITSELF

An unconventional approach to harnessing energy has created a motor that requires no fuel and produces no waste. Its inventors say it is the answer to man's transportation and power problems

BY JACK SCAGNETTI

*Rationing in Effect as Winter Catches U.S. Short of Fuel*

*Fuel Shortage May Curtail Rail Service*

*Smog-Proofed Autos Choking on Own Fumes*

*U.S. May Approve Gasoline Rationing*

*Pace Picks up in Quest for Clean Engines*

—Newspaper headlines from January, 1973

**Q**UATSTROPHIC PROBLEMS, aren't they? Not only are we taking more out of the earth than the earth has to give, but we're also using what we take to ruin the air above.

Sitting in a small laboratory in Van Nuys, California is a curious creation which, based on the results of dynamometer tests and other rigid trials, claims to be the solution. It's called the EMA (electro-magnetic association) motor and, in technical jargon, is described as "digital-pulsed," "time-phased" and "servo-controlled." Developed by EvGray Enterprises, an independent research and development firm, the unique engine runs on the principle of electro-magnetic transformation.

In terms more meaningful to the layman, the EMA motor requires no fossil fuel, recycles its own energy, creates no waste and is extremely quiet. Its size, weight and horsepower ratios are comparable to motors and turbines now in use.

The EMA's only external power source consists of four 6-volt batteries which never need recharging and which have the same life expectancy as the standard automobile battery. EvGray claims the motor duplicates the power and torque characteristics of internal combustion engines of similar size

**FUELLESS AND SMOGLISS,** the electro-magnetic engine developed by EvGray Enterprises is purportedly as powerful as internal combustion engines or turbines. The prototype shown here is the size required to fit a small truck or bus. Once the motor is installed, only the main wires running from the engine to the batteries will be exposed.

and weight, and the Federal and State Air Resources Board has granted the inventors a permit to further prove this claim by installing the EMA in test vehicles.

Edwin Gray, Sr., president of EvGray, predicts production costs of the EMA will be comparable to present motors and maintenance costs will be far less. "The EMA motor promises to make the world a cleaner place in which to live," says Gray, who has spent 12 years developing the engine. "Perfection of the EMA motor as a generating source could mean the availability of inexpensive power to underdeveloped nations."

EvGray expects the mMMA Motor—when tailored for specific applications—to become a desired replacement for virtually all power systems now in use. The full spectrum of possibilities includes: (1) industrial engines for application of portable welding generators, stand-by electric generators, portable battery chargers, portable power tools, portable lifting equipment, and industrial utility vehicles; (2) engines for agricultural equipment for use on lawn tractors, lawn mowers, soil and harvesting equipment, horticultural equipment, and irrigation booster pumps; (3) engines for building and construction equipment, including portable building equipment, concrete mixers, portable conveyors, portable compressors, and construction machinery; (4) aircraft, automotive and marine engines, including automobiles, trucks, outboard motorboats, auxiliary yacht engines, lifeboats, light aircraft, and auxiliary glider engines; (5) engines for household and recreational equipment, including small lawn mowers, snowmobiles, golf carts and snowblowers; (6) engines for heavy transportation and stationary uses, including railroad locomotives, ships, pumping sets for atomic reactors, generator sets, and jet aircraft engines; (7) miscellaneous applications, including fire-fighting pumps, air-conditioning units for buses, refrigeration units for trucks, and special military purposes (generator sets, gas turbine, starter units, etc.).

## LIGHTNING AND "ENERGY SPIKES"

Gray describes the operation of his EMA motor as "similar to re-creating lightning." He says the engineering and scientific

world has known this re-creation is possible but hasn't known how to do it. "When lightning hits the ground, causing a 10-million-volt buildup, where does energy come from to make it from a static charge to a lethal charge? Nobody really knows."

Richard B. Hackenberger, Sr., vice-president in engineering for EvGray, explains how the EMA motor system operates. "Power from the high-voltage section," says Hackenberger, "is put through a system of electrical circuitry to produce a series of high-voltage 'energy spikes.' The spikes are transferred to a small control unit, which in turn operates the major motor unit. The control unit, acting in a manner similar to that of a distributor in an internal combustion engine, regulates the spikes, determines their polarity (whether they be north or south) and directs their power to selected electro-magnets in the main unit. While this occurs, the recycle/regeneration system is recharging the batteries with 60 to 120-amp pulses. The electro-magnets are located on both the rotor and stator of the large motor. Attraction and repulsion between the two sets of magnets causes the motor to operate and generate horsepower. Once in motion, the motor recharges the batteries as a result of the recycle/regeneration system. To prevent condensation in the main cylinder, a half-pound of air pressure has to be maintained. Air is routed through the programmer for functional purposes. When the ambient temperature is 90 degrees, the motor operates at 170 degrees."

In short, the principle of the engine is to create electricity and recycle energy by the factor that every time magnets are energized off the peak of transients, a charge goes back into



**ELECTRONICS EXPERT** Richard Hackenberger, an EvGray vice-president and a former engineer with Sony and Sylvania, says electro-magnets make the unique invention run. "Attraction and repulsion between the two sets of magnets," he explains, "causes the motor to operate and generate horsepower."

the battery. It's not a constant charge, but a pulse charge of 60 amps or better; thus, the battery must be of high quality. The batteries for the EMA motor are furnished by McCulloch Electronic Corporation of Los Angeles. After extensive research and testing, EvGray chose the model 110-75 Energy



**SINCE HE WAS A BOY**, Ed Gray has been fascinated by the possible uses of magnets and electricity. Now 48, he has applied some unorthodox ideas to the challenge of creating a power source that will run in harmony with the environment. The result is the EMA, which needs no fuel and creates no waste.

Center, which is said to produce maximum power for its weight and volume over an exceptionally long life span. This is achieved partly by use of an ultra-lightweight plastic case that minimizes dead weight (energy-storing components comprise more than 90 percent of the battery's weight). Features of the battery include extra-large plates separated by indestructible glass-rubber separators and a specially formulated lead oxide composition. Two of the 6-volt batteries are used for operation, while the other two serve as a reservoir. Mallory Electric Corporation of Carson City, Nevada, has also made a major contribution toward the design of the electronic pulsing system.

#### LONG-RANGE AND POWERFUL

Electric-powered vehicles are not new, of course, but the poor energy-storage factor of batteries and their heavy, large size have thus far made them impractical for use in any vehicles requiring a long-range capacity. This drawback has restricted the market for electric power to small limited-performance vehicles. The maximum range of these vehicles when driven at 40 miles per hour has been approximately 150 miles. Range is affected by the number of stops and starts, grades traversed, and acceleration demands.

The EMA motor needs only to run at 500 rpm for the normal recharging system to work. In fact, its recharging capabilities are such that the EvGray's next version of the engine won't have an alternator or air pump. The air pump will be replaced by blades on the rotor.

"The idea of a self-sustaining electric motor," says Gray, "at first appears to go against much of the theory of electricity and conservation of energy. The EMA motor does not, however, violate the basic laws of physics, but rather utilizes them in a unique integration in a system in order to maximize

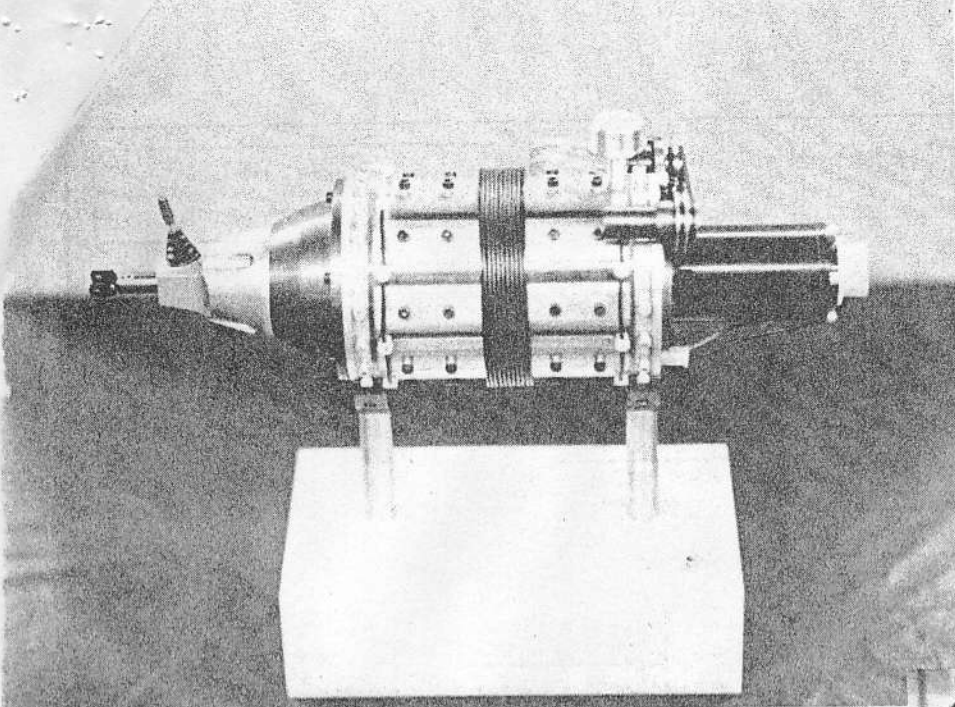

**A LITTLE BROTHER**, the functional scale model at left shows what the EMA prototype below looks like minus batteries and without the extra apparatus of the pedestal. Within the engine itself, only three surfaces make physical contact.

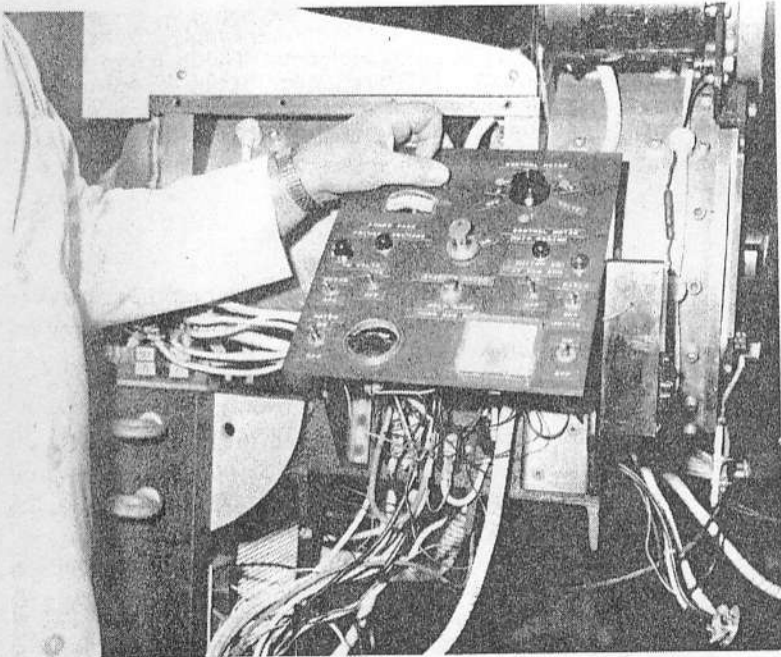

Photos by Jack Scagnetti

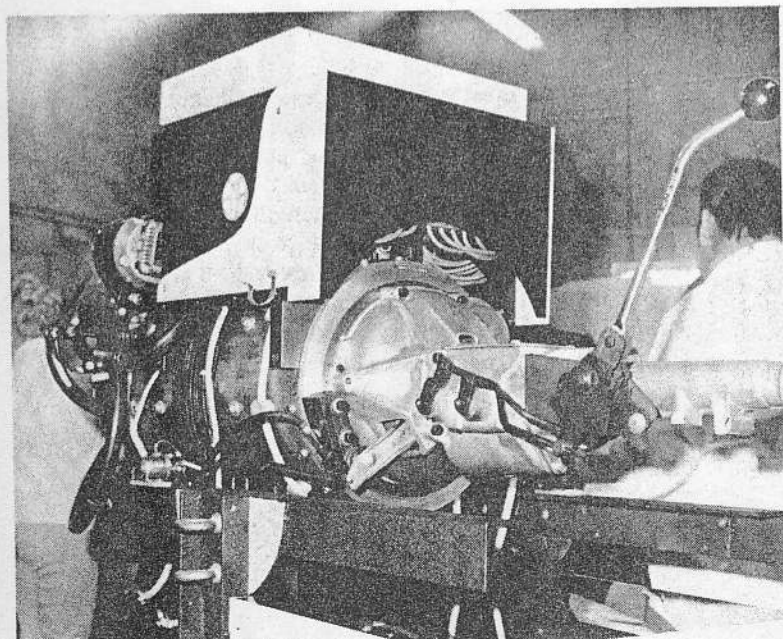
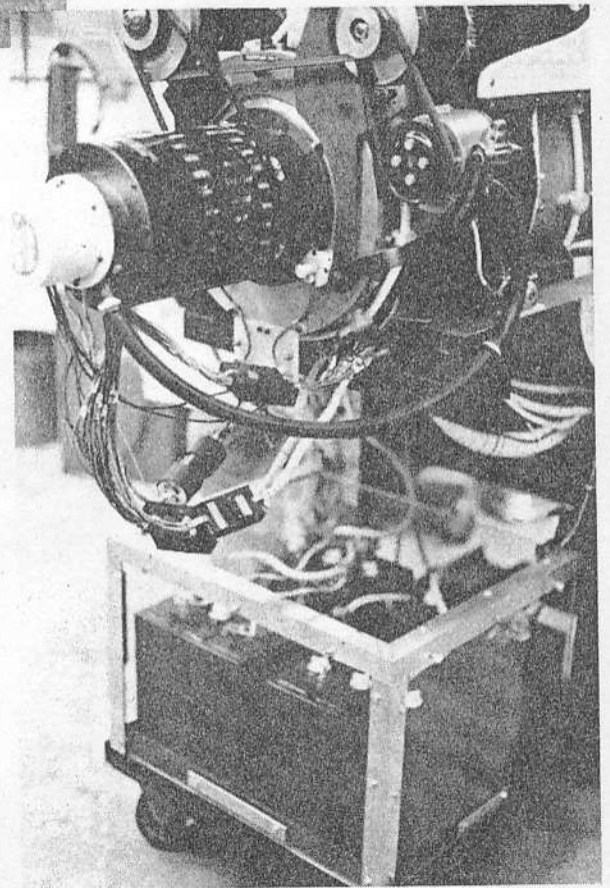

**OTHER POINTS OF VIEW** show the control board (left center) and the standard transmission (left) attached to the prototype. Gray, who ran the engine for PROBE at his laboratory in Van Nuys, says the prototype has had "considerable operating test time."

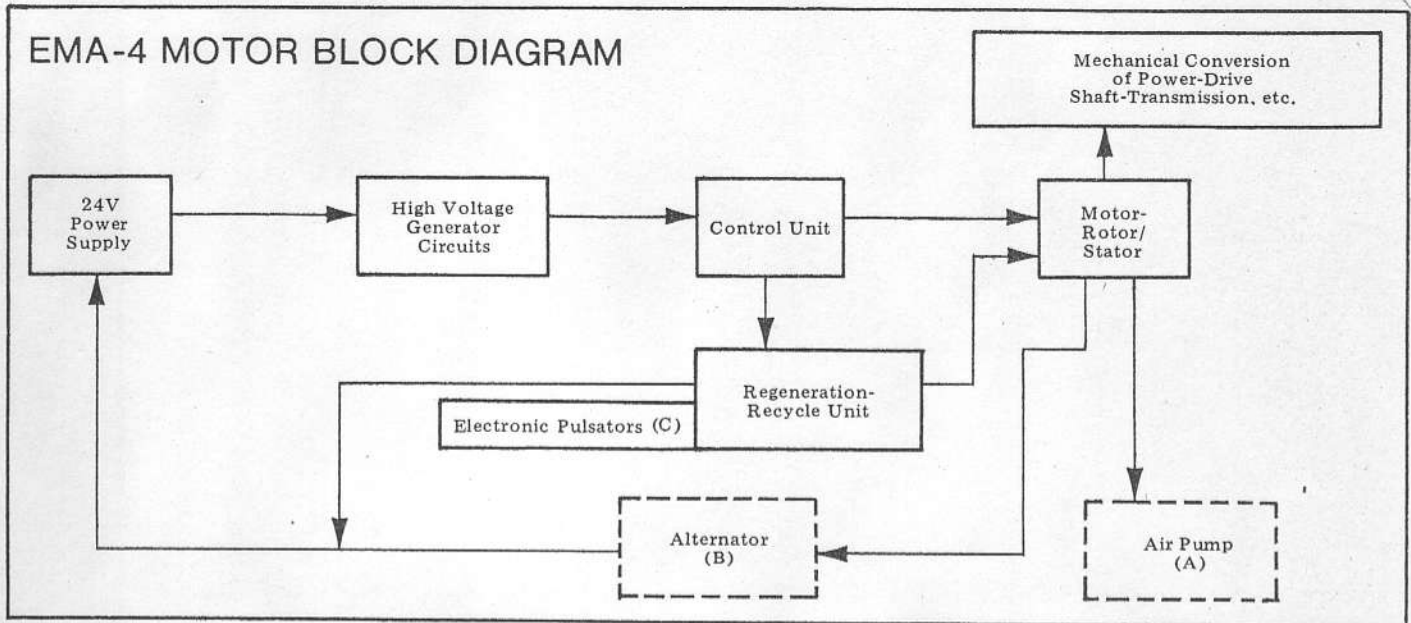

**BLOCK DIAGRAM OF THE EMA-4** shows how energy is transmitted from the four 6-volt batteries (power supply) to the various stages of the engine and returned. Both the air pump (A) and the alternator (B) are optional equipment. The air pump prevents condensation around the drum and provides added assurance of air in some environments. The alternator is not needed for most applications, including use in vehicles, but may be desirable in heavy generator rigs. The electric pulsators (C), which are contained in the regeneration-recycle unit, are capable of pulsing at 200,000 times per minute, and the pulsation at 60-to-120 amps is fed back to the batteries.



Photo by Jack Scagnetti

**GOVERNMENT RECOGNITION** of the EMA project has come from various sources, including the governor of California. Here, Gray and his wife, Evelyn, display a certificate of merit they received from Ronald Reagan.

upon the characteristics and interrelationships between electrical, magnetic, and physical components. The EMA prototype motor has had considerable operating test time and has been adapted to standard and automatic automobile transmissions."

Dynamometer tests have recorded the rpm's of EvGray's motor at 2550 constant, the torque at 66 pounds constant. Brake horsepower is 32.5. After a test run of 21½ minutes, the battery voltage reading was 25.7.

Only three surfaces make physical contact with the motor, a feature which dramatically limits friction and increases efficiency. "An internal combustion engine is only 30 percent efficient," says Gray. "Our engine is 90 percent efficient." A prime factor in friction control is the so-called "magnetic vacuum," created in the drum, which literally takes the pressure off of end bearings and allows the rotor to float within the drum.

"Our motor creates power surges—one behind the other—in micro-seconds," says Gray. "By doing this, we are able to direct the magnetic flux field. The magnetic flux is a coolant source, so we need no cooling system."

Gray says the engine is not affected by rain, heat, cold, any other type of inclement weather, or by driving through tunnels. "All this motor needs is oxygen. The only external magnetic effect is that another field system cannot operate within this same battery system. The magnetic field orientation is 360 degrees in all directions."

#### LIGHT, EASY TO MAKE

The new EMA prototype will weigh about 320 pounds, less than most present internal combustion engines. It will measure 12 inches in diameter, 18 inches in length. (Size is linear to

horsepower required.) According to Gray, further research should make it possible to reduce the size and weight through the use of lighter metals and more sophisticated circuitry.

Gray says most of the motor's components can be built in a machine shop with a mill and lathe. The exceptions are the drum itself, the electro-magnets, and a few miscellaneous items bought over the counter in an auto supply store. The company plans to enter into worldwide licensing agreements to manufacture the motor.

The safety features of the EMA are impressive. There's no fan, no exposed high-voltage component parts, no exhaust fumes, no fuel tanks to explode, and no water reservoirs to clog up, freeze or overheat. EvGray believes the reliability of the engine will be excellent, and maintenance should be minimal because there's no carbon, water, varnish or other impurities—which occur normally as a result of burning oil or gasoline—to damage parts. There is no carburetor to clean and adjust, no oil filter to change, no gas filter, smog valve, gaskets, radiator, water pump or timing chain. Plug-in type construction makes replacing parts quick and easy. Gray says the training time for EMA mechanics is less than that for mechanics working with a standard electric motor and far less than that for those preparing to work on internal combustion engines.

The EMA also favors the eardrums of mankind. Its noise emission is far less than that of all other power sources, and Gray claims there will be no increase in noise as the engine ages. In fact, electric-motor noise is almost imperceptible when properly suppressed.

Perhaps the reason Edwin Gray, now 48, has been able to create such an unconventional engine is his unconventional



“Only those in the scientific world who understand the theories of physics are able to comprehend how our motor works. There's only a handful of such persons.”

education. One of 14 children, he began tinkering with magnets and electricity as a boy. He left home when he was 15 and served a year in the U.S. Army before it was discovered he was under age and he was given an honorable discharge. During

## EMA-4 MOTOR PRELIMINARY TEST DATA

Input Power	12 volts dc (of a 24 volt dc system, making use of a 12 volt standard starter motor)
RPM	2550 RPM constant
Torque	66 lbs/constant
Horsepower	100 HP
Brake Horsepower	32.05
Foot-pounds/minute	1,057,650
Foot-pounds/second	755 lbs. (includes 110 lbs for four 6-volt batteries)
Volume	42" long x 18" wide x 22" high. (This is overall geometry, including control unit, etc.—The basic motor is a 16" dia x 24" cylinder, which can be repackaged into a 9" dia x 12" cylinder)
Test Run Time	21.5 minutes
Battery Voltage Reading at test completion	25.7 volts
Ambient Temperature	84 degrees constant
Humidity	51%
Fuel Consumption	None (other than air)
Cooling	Conduction/½ pound (flow through) air pressure
Magnetic Field Orientation	360 degrees—all directions during motor operation
Lubrication	High temperature bearing grease (2 bearings)
Vibration	Negligible
Noise Level	No direct reading taken—without shielding, no louder than small kitchen appliance, e.g., fan, etc.
Power Hazard	Fully secure—full design safety features
Start Mode	Simple push button—standard 12V starter motor
Operating Mode	Rheostat principle with switchable RPM range (500-1300-1950-2550-3350-4100 RPM's)
Physical Condition	Motor mounted on wheeled test stand—no external connections to stand.

that year, he attended an Army school for advanced engineering. After the attack on Pearl Harbor, he reenlisted, this time entering the Navy. After serving three years of combat duty in the Pacific zone, he returned to civilian life and found work in the field of mechanics. Resuming his experiments with electro-magnetic power, he seriously examined the theory of *energy used is energy spent*.

After years of research and experimentation, Gray conducted his first test of the EMA motor in 1961. The engine ran briefly and then broke down. Discouraged but not defeated, he constructed a second electro-magnetic motor, which ran for an hour and a half before failing.

A third prototype ran for 32 days attached to various automotive transmissions and test equipment. It was then dismantled for analysis, and detailed reports were prepared. After rejection by large corporations and money promoters, Gray formed a limited partnership in 1971 and constructed the fourth EMA prototype. With assistance from nearly 200 private citizens, EvGray Enterprises has spent \$1.1-million in the attempt to recycle present lost energy and redirect

magnetic forces with the EMA motor.

Dick Hackenberger, who comes from a more conventional background, compliments Gray's raw genius with 25 years of diversified functional and management experience in the engineering field. He holds an EE degree from Northeastern University and is a senior engineer in the Institute of Electrical and Electronic Engineers. Hackenberger has held positions with the Sony Corporation of America and Sylvania Commercial Electronics, and he has served as an engineering consultant to the U.S. Navy.

Other EvGray officials include Arthur M. Lange, vice-president in charge of public relations, and George C. Demos, vice-president in charge of marketing. Lange has served in management and public relations capacities with both Ford and General Motors, while Demos has worked as division general manager for Control Data, director of marketing for RCA, and president of his own manufacturing firm.

#### RAISING A FEW EYEBROWS

The electro-magnetic motor has attracted attention from important government agencies, including the Environmental Protection Agency, the Air Resources Board, and the Department of Transportation. Governor Ronald Reagan of California last year presented Gray and his wife, Evelyn, with a certificate of merit. Others indicating interest in the project are congressmen Barry Goldwater, Jr., Edward R. Roybal, Del Clawson and James C. Corman, U.S. Senator Alan Cranston, and state senators Alfred E. Alquist and Nicholas C. Petris.

John Brogan, head of the Environmental Protection Agency's advanced automotive power systems development division, says his 25-man staff has looked at approximately 20 alternate engine proposals each week for the past two years. He says nearly half of the proposals are for "perpetual motion" machines; that is, machinery that would produce continuous movement without any outside energy source. The concept of perpetual motion violates all known laws of thermodynamics.

According to EvGray, some experts believe the EMA is a perpetual-motion engine and is, therefore, invalid. Gray himself refutes this belief. "The EMA motor is definitely not perpetual motion," he insists. "Only those in the scientific world who understand the theories of physics are able to comprehend how our motor works. There's only a handful of such persons.

"The programmer directs which magnets are to be energized for what length of time and in what polarity. There are several attractions and repulsions taking place at the same time."

The search for the clean engine has seen the federal government contribute \$23-million to the development of new engines in the past two years. General Motors, spent \$36-million last year alone, and Ford laid out \$20-million. Senator John V. Tunney of California has proposed legislation to divert \$900-million from the Highway Trust Fund into a three-year crash program to develop a clean engine.

Meanwhile, Edwin Gray, after 12 years of research and development, believes he has found the answer for a comparatively meager \$1.1-million. Time will tell whether or not he is right. □

## PROBE UPDATE

A cooperative effort between parapsychology and the more conventional fields of science sets its sights on discovery in a...

# NEW UNDERSEA SEARCH FOR ATLANTIS

SETTING WHAT MAY BE A PRECEDENT in the ongoing search for Atlantis, an expedition sponsored by an American university will conduct an undersea hunt for the legendary "lost continent" this summer. Two hundred educators, students, scientists, parapsychologists and laymen will participate in the six-week project to be held in Cadiz, Spain, northwest of Gibraltar.

Leading the project is Maxine Asher, educational consultant to Pepperdine University in California and head of the Ancient Mediterranean Research Association. Co-director is Dr. Julian Nava, vice-chairman of the Los Angeles City Board of Education.

"There has never before been a large, interdisciplinary, scientific expedition for Atlantis undersea," says Mrs. Asher. "The best that there has been was a small group that went to Bimini in 1969 under Manson Valentine for the Cayce Foundation. They did find some cyclopean-type remains, but they only had a small amount of money and had to stop the research for lack of funds. Outside of that, there's

