

The "Tesla Switch" Custom Maglite Torch

by Dave Michael Rogers

This torch customization is based on discussions I had with John Bedini about a particular German battery used in WWII fighter planes.

When the LED's begin to dim, the rotary switch is turned 1/4 turn, returning the battery to a fully charged state and the LED's back to full brightness.

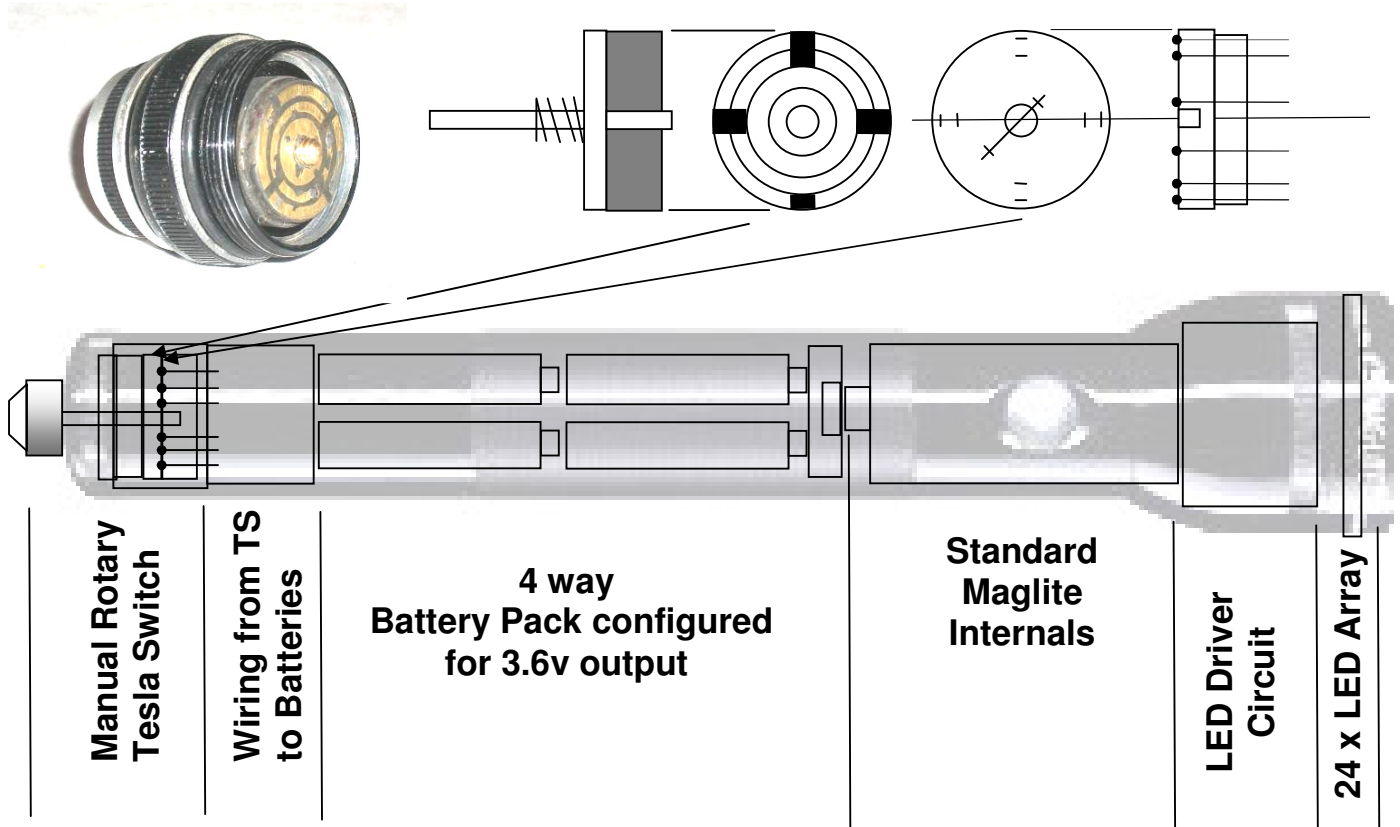
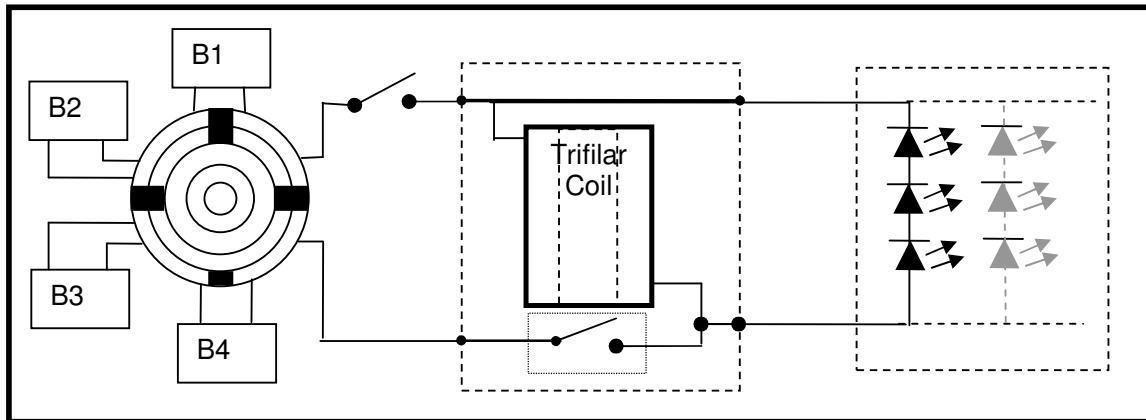

Mechanical Rotary Tesla Switch For DC Motors

By Dave Michael Rogers

→ Arrows represent slip ring brushes.

● Reverse side connection wire.

